



- 819 □ 823 □ 827
- 820 □ 824 □ 828
- 821 □ 825 □ 920
- 822 □ 826 □ 921

BODY MOUNTED COUPLERS ASSEMBLY INSTRUCTIONS

#819 includes couplers and flex-brackets to allow operation on shorter track.

#820, 920 is the standard coupler used on all applications where room and space permit.

#821, 921 is a shorter coupler used primarily on locomotives or other cars where room is too restrictive for the #820, 920.

#822 is a long straight shank coupler without draft gear box for do-it-yourself adaptations. **#823** is a long thicker straight shank coupler without draft gear box for do-it-yourself adaptations.

#824 includes couplers and brackets for mounting on cars such as and similar to the Aster caboose which use existing screws on the underbody for mounting.

#825 includes couplers and brackets for mounting on cars such as and similar to the J & M Model Pullman passenger cars which have high mounting surfaces. Existing screws on the underbody are used for mounting.

#826 includes couplers and brackets for mounting on the Aster Pennsylvania K-4 loco and tender and similar adaptations.

#828 includes couplers and long flex-brackets to allow operation on shorter radius track.

The minimum radius track these couplers will operate on depends upon the amount of overhang from the truck centering king pin to the coupler knuckle pivot pin of the particular car adaptation. We have observed no clearance problems testing on a 6 foot radius track, however, cars should be operated on the radius track suggested by the manufacturer.

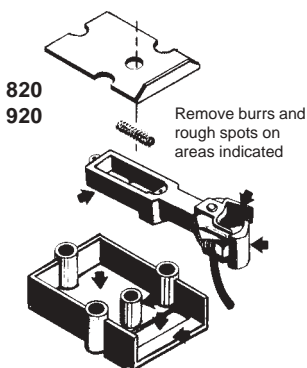
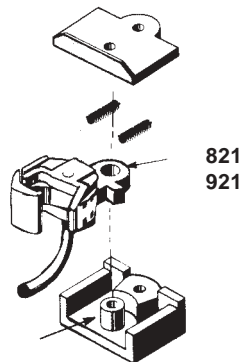

Fig. 1



#821
921

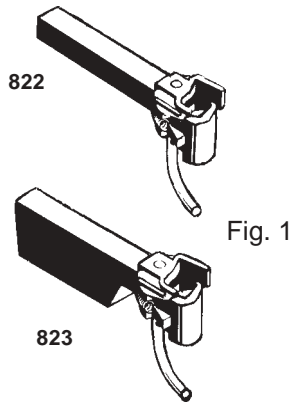

Fig. 1

Check instructions pertaining to your Packet and read thoroughly before proceeding.

#819 - See enclosure.

#820, 920 - You should have: 2 ea couplers, 2 ea draft gear boxes, 2 ea draft gear box lids, 3 ea centering springs, 1 ea knuckle spring, 4 ea 2-56 screws and 4 ea 2-56 nuts.

#821, 921 - You should have: 2 ea couplers, 2 ea draft gear boxes, 2 ea draft gear box lids, 6 ea centering springs, 1 ea knuckle spring, 4 ea 2-56 screws and 4 ea 2-56 nuts.

#822 - You should have: 2 ea couplers, 1 ea knuckle spring and a length of .009 spring wire. No draft gear boxes are included. These couplers are for do-it-yourself adaptations where #820, 920 or #821, 921 won't fit.

#823 - You should have: 2 ea couplers, 1 ea knuckle spring and a length of .009 spring wire. No draft gear boxes are included. These couplers are also for do-it-yourself adaptations where a thicker shank is required.

#824 - You should have: 2 ea #820, 920 couplers, 2 ea draft gear boxes, 2 ea draft gear box lids, 3 ea centering springs, 1 ea knuckle spring and 2 ea brackets.

#825 - You should have: 2 ea #820, 920 couplers, 2 ea draft gear boxes, 2 ea draft gear box lids, 3 ea centering springs, 1 ea knuckle spring, 2 ea small brackets and 2 ea large brackets.

#826 - See enclosure.

#827 - You should have: 2 ea couplers (1 modified #823 with slotted shank, 1 #821, 921), 3 ea centering springs, 4 ea short silver-colored springs, 1 ea knuckle spring, 1 ea tender mounting bracket, 2 ea 1/16" washer shims and 1 ea .008 shim.

#828 - See enclosure.

Note: Extra springs are provided should any get damaged or lost. All springs are made of stainless steel so they will not be affected by outdoor use.

ASSEMBLY

1. IMPORTANT: Before assembling couplers, check arrow-marked areas shown in Fig. 1 for burrs and rough spots. Remove with fine file or an X-acto® knife.

2. Burnish the surfaces marked by arrows in Fig. 1 and inside entire knuckle area with Kadee® Greas-em® #231 (a fine, dry lubricant specially suited for Kadee® couplers). DO NOT skimp on steps 1 and 2, they are mandatory for smooth, trouble-free coupler performance.

3. Place coupler into draft gear box as shown in Fig. 2. Add a little more Greas-em and work coupler back and forth within box to further burnish.

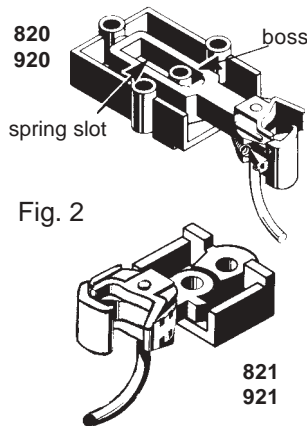

Fig. 2

4. #820, 920 - Hold coupler and draft gear box together and install centering spring into spring slot using tweezers or a small screwdriver between the end coils (Fig. 3A). Place lid on draft gear box being careful not to dislodge centering spring.

#821, 921 - Swing coupler to either side and install the first centering spring with a small screwdriver or tweezers as shown in Fig. 3B. Now swing the coupler to collapse the installed spring and hold in place with your thumb. This will give you room to fit the second centering spring in place. After installing both springs, allow the coupler to center itself. Then, assured the springs are properly seated, carefully place draft gear box lid on.

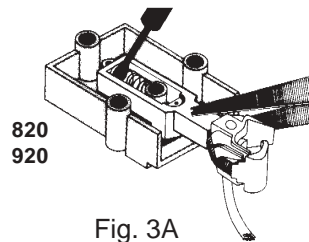

Fig. 3A

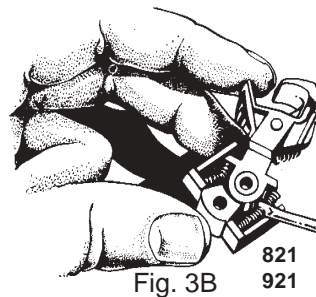

Fig. 3B

5. Test coupler centering action by freely working it back and forth. If it doesn't work freely and snap back to the center position, take coupler and draft gear box apart and start over. It is possible the springs aren't properly set in place or a burr is preventing proper movement.

6. Coupler knuckle springs are installed at the factory. If one should come out during mounting, replace as follows: Insert small screwdriver blade between coils at one end of spring, then place other end of spring over either of the cone-shaped projections in the knuckle spring slot. Compress spring until other end can be slipped over opposite cone (Fig. 4). Use only #1 gauge knuckle springs designed for this purpose. Any substitutions will not allow the coupler to work properly.

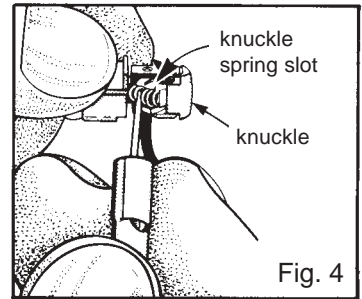

Fig. 4

7. Coupler gear box assembly is now ready for mounting. **Note:** To make handling easier, it may be best not to install the centering springs until you are ready for the actual mounting. **#821, 921 only** - If after extended use, the coupler does not snap back to center as when new, it is because the uncoupling action causes the spring to take a shorter set. To correct this, simply remove and switch springs from one side to the other.

MOUNTING

1. To permit standardization of your rolling stock and interchange of equipment on different model railroads, we recommend a mounting height of 1.062" (1 1/16") from top of rails to center line of coupler (Fig. 5).

2. To mount coupler gear box assembly at this height, it may be necessary to alter the coupler mounting surface. Fig. 5 shows the distance from mounting surface to top of rail must be 1.203" (approx. 1 13/64"), which includes half the thickness of the coupler gear box.

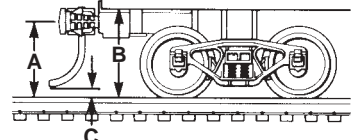

A: Railtop to coupler centerline = 1.062" (1 1/16")
B: Railtop to car underbody = 1.203" (1 13/64")
C: Trip pin clearance = .125" (1/8")

3. Various methods will be used to mount the couplers, depending on your particular application. Some installations will simply be screwed into place while others may require using mounting brackets. Alterations required to the car and/or draft gear box should be done as carefully and accurately as possible. For maximum performance, it is important the coupler be mounted at the correct height, directly on the car width centerline. The following are some procedures and typical examples to serve as guidelines.

4. Turn car over and look for obstacles which might prevent the gear box from laying flat in position. The first step is to remove the old coupler. If possible, use double-back adhesive tape to hold new coupler/gear box assembly in position so you can check distance from center of coupler to top of rail. Once you have established this measurement, you can determine if you must shim gear box down or cut the underbody to raise the surface for the coupler gear box. On the #820, 920 coupler, you must also decide which two of the four gear box mounting holes you will use.

5. If coupler mounting surface is uneven, or too high from the track, use one or more plastic shims to support the coupler gear box assembly (Fig. 6). In many cases, you can place shims on, or between, the center sills and end sills of the car underframe to provide a solid base for the gear box. Temporarily mount shims. Then set gear box assembly in place and mark location of mounting holes on shims. Remove and drill and tap shims in the marked locations for 2-56 screws. Remount shims in their original position, this time using screws or Super Glue to hold them solid. The coupler gear box assembly can now be screwed into place. An alternative if the coupler is too high, is to glue shims between the body bolster and the truck side frames (Fig. 7), which lowers the car.

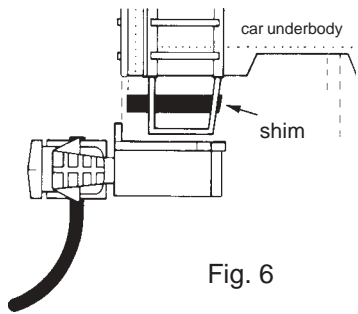

Fig. 6

Note: When using metal screws in plastic, tapping of the hole is not required. After drilling a 5/64" hole, the screw will self-tap. An alternative to tapping the holes is to drill 7/64" holes through and use the 2-56 screws and nuts to secure the gear box. The metal screws can be cut to the required length with a fine saw. Before cutting, screw on a supplied nut, so that by removing it after the cutting, the nut will serve to clean up the thread ends.

6. If coupler mounting surface is too low, the underframe must be cut to raise the coupler to the proper height. Carefully lay out the area to be cut so the gear box will be level, centered (referring to car width), and at the correct height. It may be best to remove most of the material with a chisel or small saw, leaving finish material which can be carefully removed with a fine file until desired fit and depth is achieved. Placing washer shims between the truck bolster and the car body bolster is an alternative to cutting the car body underframe. Another option is to eliminate the draft gear box lid and file the mounting holes flush with the box. This will raise the coupler about 1/16".

7. Installation of the Kadее® coupler on the Precision Scale Iron Horse Model® gondola is a simple procedure. Remove the end sill coupler carrier by taking out the two small screws. File the lip off the Kadее® draft gear box lid so the coupler gear box assembly can be mounted. If mounting screws are not supplied with the car, carefully drill out the two existing outside mounting holes with a No. 50 drill and tap with a 2-56 tap. (A 2-56 tap and drill packet is available from Kadее®. Order stock #246). Now install coupler gear box assembly after cutting screws to proper 3/8" thread length as mentioned in earlier note. The air angle cock and hose may have to be removed or bent out of the way for clearance. The Precision Scale Iron Horse Model® freight car is a similar installation except the lip of the draft gear box lid need not be filed off.

8. Some installations will require additional modifications or brackets. Here are some examples: The Aster Pennsylvania K-4 locomotive and tender (#826) and the Aster NYC Hudson locomotive and tender (#827) contain complete instructions along with the couplers and parts required for installation in their respective packets.

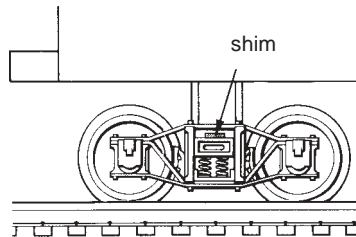

Fig. 7

The J & M Model freight car requires using shims and alteration of the gear box to accept the #820, 920 coupler. Remove the old coupler and brass insert from end section of center sill, which runs down the center of the underbody. You may have to loosen nut on the kingpin, under truck, and lift up on center sill so insert will drop out. Use small saw to remove side screw holes (nubs or ears) of gear box and then a sharp file to remove equal amounts of plastic from each side of gear box and lid, until they will just slip into center sill. Make up two shims about 3/64" thick (cardboard can be used). One should be about 1/2" x 1 1/2" and the other 1/2" x 5/8". Place large shim into the center sill and, if necessary, file car body end until it is flush with the shim. Place small shim on back of the gear box (area marked #1 805-1) and slip entire assembly into center sill. Use a screw or small dowel in top hole to prevent coupler from sliding out.

Some cars, such as the J & M Model Pullman passenger car and Aster caboose, can utilize existing screws on the underbody to mount the #820, 920 couplers when used with special mounting brackets. The #824 packet is used when the gear box is mounted flush to the underbody as on the caboose. The #825 packet is used when the mounting surface is too high and the gear box must be shimmed down as on the Pullman passenger car. (Both #824 and #825 packets include brackets and couplers.) Detailed instructions regarding bracket use and layout of hole patterns are included with the individual packets.

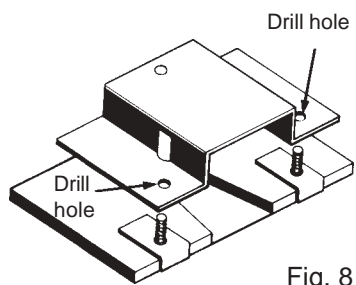
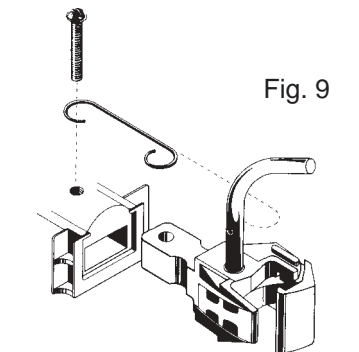

Fig. 8

Installing Kadее® couplers on the Samhongska hopper car is a simple procedure with our #822 coupler. After removing the old coupler, cut 1/2" off the end of the shank of the new Kadее® #822 coupler. File the underside of the remaining coupler shank slightly until it easily slides into the slot on the car (be sure to file off any excess paint inside the slot). Drill a 5/64" hole through the shank 1/8" from end (Fig. 9). Cut a length of the supplied wire about 1 1/4" long and using tweezers or needle nose pliers, form a small loop at one end into which the screw is inserted. Position Kadее® #822 coupler inside slot and install the screw assured the hole placement is in line and correct. Swing wire along side coupler trip pin and tighten screw, holding the spring in place. Now, using tweezers or needle nose pliers, wind wire around trip pin forming spring (Fig. 9). Once loop locations are marked, coupler can be disassembled to allow further bending and trimming of spring. Also, file the sides and back of the shank as shown to allow coupler to swing. After tightening the screw, be sure the coupler will swing freely and properly return to center. If not, loosen the screw and hold spring slightly to either side while retightening the screw.



9. After mounting the coupler/gear box assembly, check to see if the coupler has adequate swing for proper operation. Place two cars with #820, 920 body-mount couplers on an S-curve, as shown in Fig. 10, so couplers are mismatched as much as possible. By swinging the couplers together with your fingers, they should move enough to engage as in Fig. 11. If not, remove coupler gear box assembly, disassemble, and cut gear box as shown in Fig. 12. This will allow further movement of the coupler. **This can only be done on the #820, 920 coupler.** Be sure to file smooth any rough spots that remain after cutting.

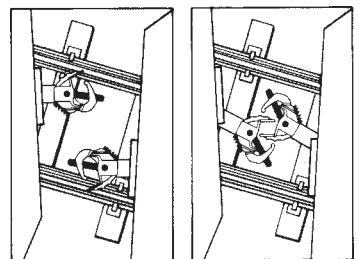
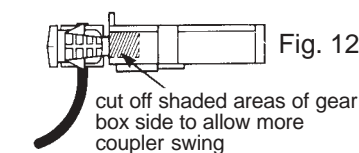

Fig. 10

Fig. 11



FIVE FUNCTION HEIGHT GAUGE

Use the Kadее® #829 Height Gauge for #1 Scale couplers. Align the knuckle of the gauge with the coupler being checked.

OPERATION

One of the many desirable features of Kadее® #1 Scale Magne Matic® couplers is their ability to perform delayed uncoupling. **TO COUPLE:** Simply push cars together. Upon touching, the operating knuckles move to opposite sides then couple in a closed position. Only a "feather touch" is required to couple. **TO UNCOUPLE:** Each coupler has a wire or "trip pin" extending down from its knuckle, towards the track, that looks like an unhooked air hose. When stopping a pair of couplers over the magnetic uncoupler (you may find it best to pull the train past the magnet, then back the cars over it), you create slack between the couplers which allows them to be drawn open by the magnetic force acting on the two trip pins (see No. 1 below). Now, when you pull forward, the couplers disengage. At this point, magnetic force will draw the couplers off-center (No. 2). Couplers will hold this position as long as they remain over magnet. When you back up, bringing couplers together again over the magnet, they will not recouple, but will mismatch in the "delayed" position (No. 3). With a single uncoupling ramp, you can set the couplers on one car, or a string of cars in the "delayed" position for spotting cars at several points beyond the uncoupler. Just push the car or cars to the desired location and drop off. As you pull forward again, the two couplers in the "delayed position" separate and snap back to their normal centering position, ready for recoupling (No. 4). As you can see, "delayed action" uncoupling has unlimited possibilities for realistic operation of your railroad. Kadее® couplers work even better than the prototype because they work automatically, with nothing touching them.

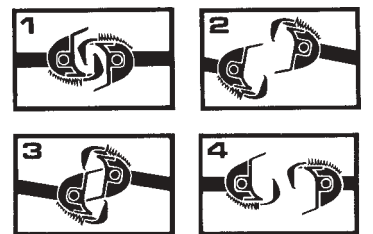

Use Kadее® #840, 841, 842, and 844 Magnetic® uncouplers with our #1-Scale couplers. The #840 and 841 uncouplers are mounted in the track section of your choice, either LGB (#840) or Kalamazoo (#841). #842 uncouplers come without track and are for mounting in LGB, Kalamazoo or other similar tracks. Cutting of the track is required and complete instructions are included. #844 uncouplers also come without track and are for use in LGB and similar types of track but no cutting of the track is necessary. If other kinds of magnets are substituted for the Kadее® magnetic uncoupler, we cannot guarantee the satisfactory operation of our couplers. Use Kadее® Greas-em® #231, the dry lubricant recommended for use with all Kadее® Magne-Matic® couplers. Greas-em® #231 will not attract the dirt and dust that gums up the inside of couplers as does oil, grease or other lubricants.

