

ATLAS KATO - JAPAN

#38 COUPLER CONVERSION

1. Remove Atlas retainer pin and existing couplers.
2. Modify pilot coupler opening to make it wide enough to accept 30-Series Draft Gear Box width of 5/16". File equal amounts from each side and if necessary a small amount from bottom of opening, do not file top of opening.
3. Assemble #38 Coupler with coupler on bottom and Spring on top. Do not use lid.
4. Insert coupler assembly into coupler opening and secure with Atlas retainer pin.
5. Check for correct coupler height, function, and clearance and make any adjustments necessary.

ALCO RSD 4/5

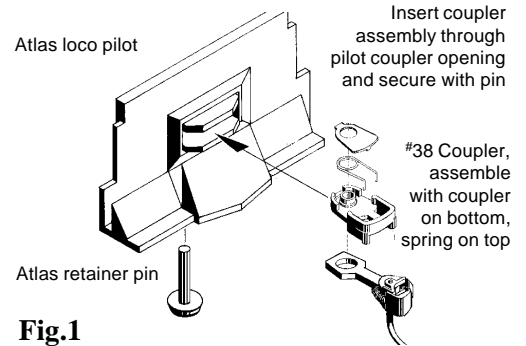

Fig.1
#38 Installation